

USING THE LOW POWER WIRELESS NETWORK FOR OBJECT POSITIONING

Martin Lauterbach¹, Ondřej Karas², Michal Lauterbach³

Summary: The article describes a system for object positioning with use of low power wireless network. In the introduction there are outlined possibilities of distance measurement in a wireless network. The first part presents the built system using the received signal strength (RSS) method for distance measurement. The second part deals with distance measurement in the network. The third part describes a positioning method based on object distance measurement from multiple locations. Similar systems are used to track goods in storehouses and production halls.

Key words: wireless networks, received signal strength, goods tracking, SimplicITI, distance measurement, positioning.

INTRODUCTION

Increasing integration and power reduction of electronic devices allow us to build wireless networks with long-term functionality powered only by primary cells. These networks are mainly used in home automatization and in building security systems. This article describes possibilities of position estimation in these networks. On this basis an idea of wireless elements network used for position estimation in areas where it is not possible to use GPS arises. Similar systems are used for monitoring of goods in storehouses and production halls. It can be used also for tracking and monitoring of moving equipment.

A primary condition for estimation of position is a possibility to estimate the distance between two points. In these positions there will be placed elements of our network. Furthermore, we have to select the method which will be used for measurement of distance.

The article (2) describes a very accurate measurement by the TDOA (time-difference-of-arrival) method. A high measurement accuracy needs a high-quality receiver with a complicated construction therefore it is not suitable for a cheap and low-power solution.

The second option is to measure the delay caused by a signal propagation in space. This is called the time-of-flight (TOF) method. System using this method is outlined in the article (3). In this case the measurement is based on a double-path delay, ie. the total propagation delay of the interrogation and the reply. If we consider that the time of propagation of signal is approximately 3.3 ns per 1 m, it is not easy to found a simple and cheap solution offering such time resolution.

¹ Ing. Martin Lauterbach, University of Pardubice, Faculty of Electrical Engineering and Informatics, Department of Electrical Engineering, Studentská 95, 532 10 Pardubice, E-mail: martin.lauterbach@student.upce.cz

² Ing. Ondřej Karas, University of Pardubice, Faculty of Electrical Engineering and Informatics, Department of Electrical Engineering, Studentská 95, 532 10 Pardubice, E-mail: ondrej.karas@student.upce.cz

³ Michal Lauterbach, University of Pardubice, Faculty of Electrical Engineering and Informatics, Department of Information Technology, Studentská 95, 532 10 Pardubice, E-mail: michal.lauterbach@student.upce.cz

On the other hand most of circuits used for construction of wireless sensor networks monitors the received signal strength (RSS). This parameter application is described in the article (4).

A suitable wireless solution could be found using an integrated low-power microcontroller with the circuit CC430F513x (5) from Texas Instruments, fitted with a RSSI (received-signal-strength-indicator). A position estimation system based on this integrated circuit using RSS method is described below.

1 SYSTEM ARCHITECTURE

A position estimation system of a minimal cost and maximum simplicity was the main goal of our design. The system arrangement is shown in the figure (1). The system is composed of several end devices, with known positions and of one device estimating its own position (the locating node). It is possible to connect PC to one of the end devices to provide system configuration.

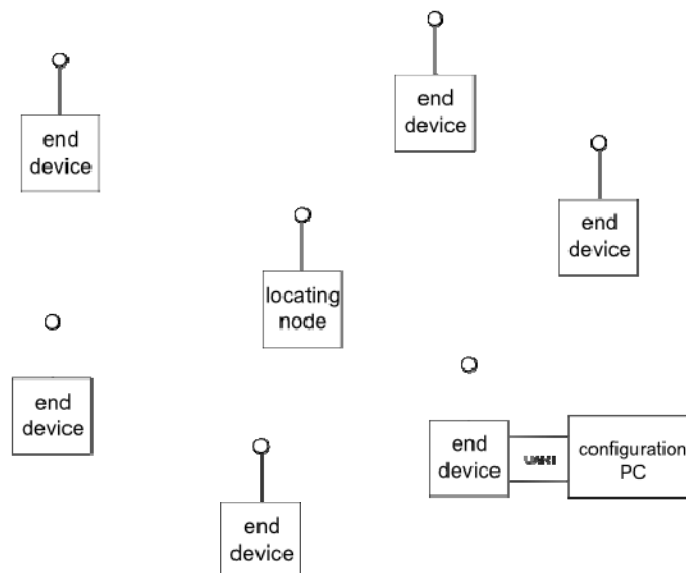

Source: Author

Fig. 1 – System architecture

1.1 Hardware

All devices in the system have the same hardware. As the base of each device the integrated circuit CC430F5137 from Texas Instruments was chosen. The given circuit contains a low-power 16-bit microcontroller MSP430 and an RF communication circuit CC1101 (6) in one package. Only several passive components are necessary (crystal 26 MHz, impedance matching of RF output, decoupling capacitors etc.) to add to build the whole device.

System is working at frequency of 868 MHz in the ISM band. A monopole antenna with vertical polarization was chosen as an optimal solution because of its smooth horizontal radiation pattern. The antennas of all the devices in the system should be situated in the same height to eliminate effects of their radiation pattern.

The power supply has a range of from 2.2 V to 3.6 V. It enables to supply devices directly from two alkaline 1.5 V cells. Peak current consumption of one device is less than 30 mA. Average value is below 1 mA for the end device. An average current value for the locating device depends on the network size.



Source: Author

Fig. 2 – The end device on the tripod

1.2 Software

Texas Instruments provides support for their circuits in the form of a complete software solution SimpliciTI (7) for wireless network. It is a network stack where the user is concerned only with an application layer. In the built network based on SimpliciTI it means the RF interface, the media access layer and the device addressing.

SimpliciTI together with mentioned circuits makes network with packet data transmission. For each received packet an information about the received signal strength (RSS) is produced, which is subsequently used for the transmitter to receiver distance determination.

2 DISTANCE MEASUREMENT

Principle of the distance measurement is described in details in the article (4). Here we use only a simplified model (1) of the received signal strength dependence on the distance:

$$P_R = P_T G_T G_R \left(\frac{\lambda}{4\pi d} \right)^2 \frac{1}{L} \quad (1)$$

where P_R is the received signal power, P_T is the transmitted power, λ is the wavelength, d is the transmitter to receiver distance, L is the system loss

We can easily transform the equation (1) into a logarithmic form (2). It's better for us because the RSS information from the RF part of the chip is available in *dBm*.

$$P_{RdBm} = 10 \log_{10} \left(P_T G_T G_R \left(\frac{\lambda}{4\pi d} \right)^2 \frac{1}{L} \right) \quad (2)$$

Then we get the following equation:

$$P_{RdBm} = P_{TdBm} + G_{Tdb} + G_{Rdb} + 20 \log_{10} \left(\frac{\lambda}{4\pi d} \right) - L_{db} \quad (3)$$

Now we need to express the dependence of the distance d on the received signal strength by:

$$d = \frac{\lambda}{4\pi} 10^{\left(\frac{P_{TdBm} - P_{RdBm} + G_{Tdb} + G_{Rdb} - L_{db}}{20} \right)} \quad (4)$$

In our system the transmitted signal power $P_{TdBm} = 0$ dBm. All the devices in the network use omnidirectional antennas with gains approximately 2 dB. It's difficult to estimate the system loss L , but we can do the calibration in a known distance to obtain the system loss including the antenna gains.

3 POSITION ESTIMATION

All the used devices are assumed to be in a two-dimensional cartesian space and the positions of the end devices are known. We have measured the distances of the positioning device from the end devices and now we must find the most probable locating device position.

To get good results we should use as much end devices as possible. But then we will get an overdetermined system. A possible solution of this problem is to minimize the sum of the squared errors.

The distance between two devices in 2D space could be expressed as follows:

$$d_{cn} = \sqrt{(x_{LD} - x_{EDn})^2 + (y_{LD} - y_{EDn})^2} \quad (5)$$

where d_{cn} is the distance between the locating device and the n -th end device, x_{EDn} , y_{EDn} are coordinates of the n -th end device and x_{LD} , y_{LD} are coordinates of the locating device.

The measured distance d_{mn} contains an error ε_n and we can write:

$$d_{mn} = d_{cn} + \varepsilon_n \quad (6)$$

The final estimation of the locating device coordinates we will get after minimization of the expression (7) with respect to these coordinates:

$$\Lambda = \sum_n \varepsilon_n^2 = \sum_n \left[d_{mn} - \sqrt{(x_{LD} - x_{EDn})^2 + (y_{LD} - y_{EDn})^2} \right]^2 \quad (7)$$

4 EXPERIMENTAL RESULTS

A measurement of the received signal power on distance dependence has been executed with two nodes of the described system to examine the received signal strength model (3). Results of an outdoor measurement at a flat grassed terrain are shown in the Fig. 4. As we can see the measured values does not track the proposed simple RSS model R^{-2} (2) but it could be fitted much better by the R^{-3} response. This declination of the observed

characteristics may be caused by the terrain vicinity and it could be included by using a more appropriate model in the distance computations. The residual fluctuations of the measured values around the smooth theoretical curve of about ± 3 dB are probably due to irregular signal earth reflections, specific for the particular place and they could be encompassed by a preliminary measurement of the RSS at all the end devices over the whole operating area.

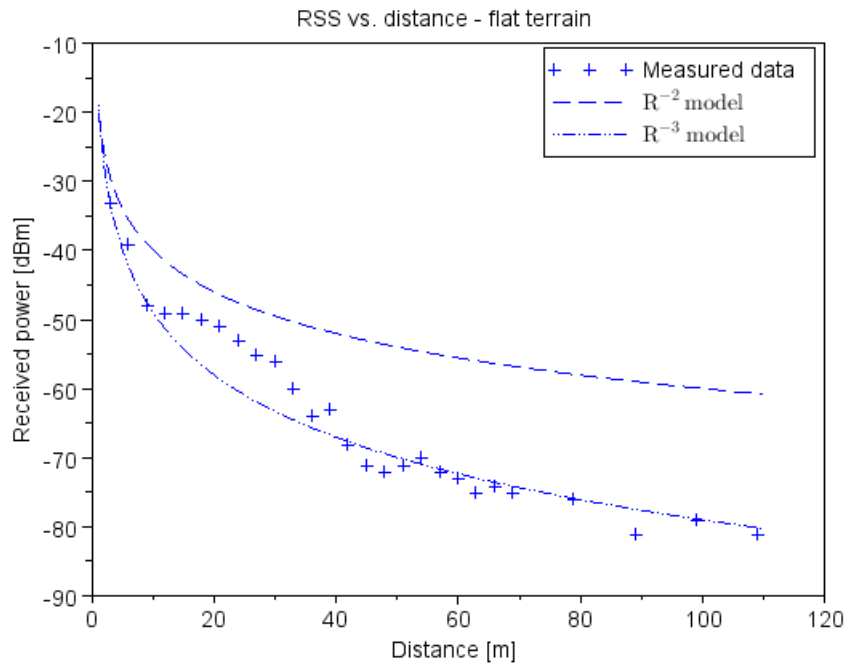

Source: Author

Fig. 3 The received signal power dependence on the distance at a flat terrain.

The dependence of the received signal power on distance measured at a corridor inside a building is shown in the Fig. 5. We may see that now the fluctuation of the measured power due to reflections from the ground, surrounding walls and the ceiling are about ± 10 dB. It seems, that application of the described method in this situation is doubtful.

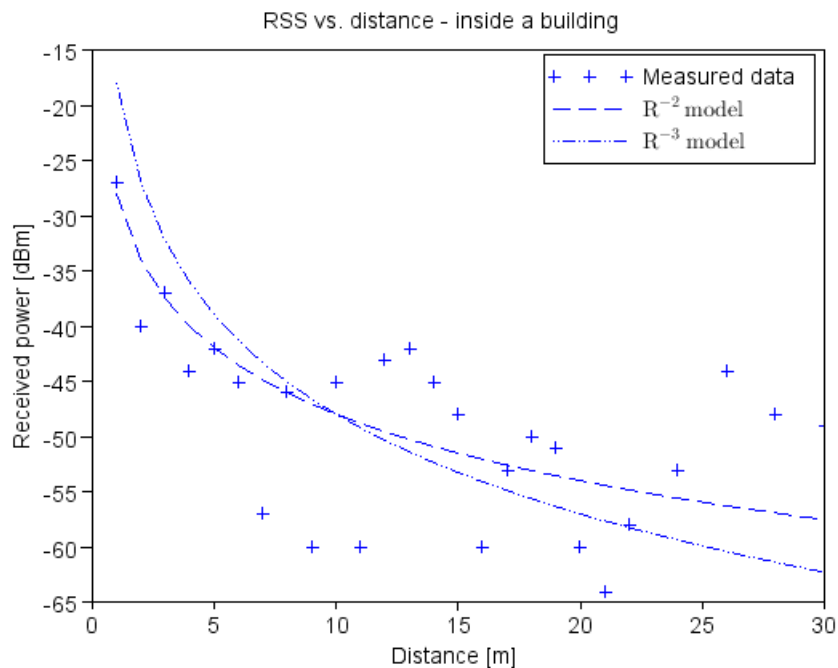

Source: Author

Fig. 4 The received signal power dependence on the distance inside a building.

CONCLUSION

The subject of this article was to present a simple and cheap solution for a position estimation without the use of GPS. The presented system is built on a single chip from Texas Instruments, working at the 868 MHz ISM band.

The article describes a distance measurement method based on the received signal strength measurement obtained from the RF part of the integrated circuit. A simple propagation model suitable mainly for an open area was used.

Position estimation is done using the least squares method. This method is appropriate for a stationary system without any movement.

The system could be further improved by a better signal model for indoor distance measurement and for moving objects by the position estimation using the Kalman filtration.

ACKNOWLEDGEMENT

The described research was supported by the Czech Ministry of Education, Youth and Sports, project No. SGFEI 02/2012.

REFERENCES

- (1) PATWARI, N., ASH, J.N., KYPEROUNTAS, S., HERO, A.O., III, MOSES, R.L., CORREAL, N.S. *Locating the nodes: cooperative localization in wireless sensor networks*. Signal Processing Magazine, IEEE, vol.22, no.4, pp. 54- 69, July 2005
- (2) SCHWARZER, S., VOSSIEK, M., PICHLER, M., STELZER, A., *Precise Distance Measurement with IEEE 802.15.4 (ZigBee) Devices*. Radio and Wireless Symposium, IEEE, vol., no., pp.779-782, 22-24 Jan. 2008
- (3) ADLER, S., HILLEBRANDT, T., PFEIFFER, S., SCHILLER, J., WILL, H. *Distance Measurement in Wireless Sensor Networks with low cost components*. International Conference on Indoor Positioning and Indoor Navigation (IPIN), Portugal, 2011
- (4) XU, J., LIU, W., LANG, F., ZHANG, Y., WANG, C., "*Distance Measurement Model Based on RSSI in WSN*". Wireless Sensor Network, Vol. 2 No. 8, 2010, pp. 606-611
- (5) "*CC430F5137 datasheet*" Texas Instruments, Texas, USA. [Online]. Available: <http://www.ti.com/lit/ds/symlink/cc430f5137.pdf>
- (6) "*CC1101 datasheet*" Texas Instruments, Texas, USA. [Online]. Available: <http://focus.ti.com/lit/ds/swrs061f/swrs061f.pdf>
- (7) "*SimpliciTI Overview*" Texas Instruments, Texas, USA. [Online]. Available: <http://www.ti.com/lit/ml/swru130b/swru130b.pdf>