

CONCEPT OF MODERN CONTROL SYSTEMS ON TWO STROKE REVERSE UNIFLOW COMBUSTION ENGINE

Martin Melichárek¹

Summary: Next level of passenger vehicles engines evolution is needed to comply with fuel economy and pollutant regulation legislative requirements. Turning a combustion engine with modern control systems into reverse uniflow two-stroke engines improves the power density of the engine and minimizes negative aspects of using the classic two-stroke engines. Variable valve timing allows control of the intake stroke, forced induction by supercharger substitutes intake into two-stroke engine crankcase, high pressure direct fuel injection eliminates fuel losses caused by overlapping intake and exhaust strokes. Future research will focus on the new design proof of concept and particular technical solutions.

Key words: uniflow two-stroke engine, valvetrain, forced induction, direct fuel injection.

INTRODUCTION

Due to continually more strict emission regulation legislative and raising fuel prices, automotive producers build the new generation of cars with focus on improving the fuel consumption, overall cars efficiency and measures reducing pollutants in exhaust gases. Current automotive design trends utilize the engine downsizing method, more precise fuel with air mixture preparation based on the current mode of engine operation by the direct fuel injection and flexible control of air intake into combustion chamber process by the variable valve timing.

This paper presents the idea of going further in the engine downsizing while keeping the engine power output on required level by designing the engine with all the current control systems of the fuel mixture preparation as used in modern four-stroke internal combustion engines to be operated in two-stroke cycle.

Each cylinder of the two-stroke engine runs in power stroke within every revolution, while the four-stroke engine needs two revolutions to repeat the power stroke in any particular cylinder. Enabling engines with current design features to deliver power through the power stroke in every revolution would allow additional level of engine downsizing and engine weight reduction for the car models that are sold today. Or more-cylinder engines might be replaced by less-cylinder engines the same way as with forced induction application some car models switched from eight cylinders to six or from six to four.

Smaller engines with higher power density will allow designing cars that are more compact, lighter, with lower aerodynamic drag and better utilization of the inner vehicle space.

¹ Ing. Martin Melichárek, Brno University of Technology, Faculty of Mechanical Engineering, Institute of Automotive Engineering, Technická 2896/2, 61669 Brno, Tel.: +420 777 057 750, Fax: +420 541 143 354, E-mail: y129042@stud.fme.vutbr.cz

1. RECENT DEVELOPMENTS OF TWO-STROKE COMBUSTION ENGINE TECHNOLOGY

1.1 Two-Stroke Engine Retrofit Project

Between years 2005 and 2007 in Philippines there was running a project “Two stroke engine retrofit kit with direct fuel injection” under governance of non-profit organization Envirofit International with cooperation of Australian company Orbital Corporation, which develops direct fuel injection systems for various engines (1). The project goal was to create a solution for south-east Asia region, where classic two-stroke engines are estimated to power about 100 million transportation vehicles such as bikes, scooters and tuk-tuk tricycles. As a result the retrofit kit for engine Yamaha RS 100T was developed and successfully tested in real Philippines traffic. The retrofit kit is sold for 350 USD to the customer.

According to Envirofit International one vehicle propelled by an outdated two-stroke engine would produce the equal quantity of pollutions as fifty modern personal cars. During the project pilot retrofit kit was tested on 13 tuk-tuk taxi at Philippines with average 5000 km driven per unit. Retrofit kit results are in Tab. 1.

Tab. 1 – Retrofit kit application impact on emissions

Measure	Value
HC emissions	89% reduction
HC emissions at idle RPM	90% below DENR ² norm (4500 ppm)
CO emissions	76% reduction
CO emissions at idle RPM	90% below DENR norm (4,5%)
CO ₂ emissions	26% reduction
Fuel consumption	35% reduction
Engine lubricant consumption	50% reduction
Particulate emissions (smoke)	80% reduction

Source: Envirofit International

The retrofit kit for Yamaha RS 100T contains the following components:

- fuel injector,
- air injector,
- cylinder head,
- fuel pump,
- oil pump,
- air compressor,
- engine control unit,
- charging system,
- wiring harness.

² DENR is Philippines Department of Environment and Natural Resources

1.2 Two-Stroke engine with pivotal piston

New Zealand company Pivotal Engineering was in 2005 awarded by SAE with Automotive Engineering International Innovation Award for a new design of two-stroke engine with the pivotal piston (2). Motivation of pivotal piston engine development was to gain high power density while keeping the reliability, enabling long durability and reduction of lubricant consumption. Pivotal piston eliminates two-stroke engine piston problem, when due to necessary higher clearance between piston and cylinder wall the piston makes rock and slap movements while traversing through the cylinder up and down. Pivotal piston is attached to the engine block by a pin that guides the piston in the cylinder as depicted on Fig. 1.

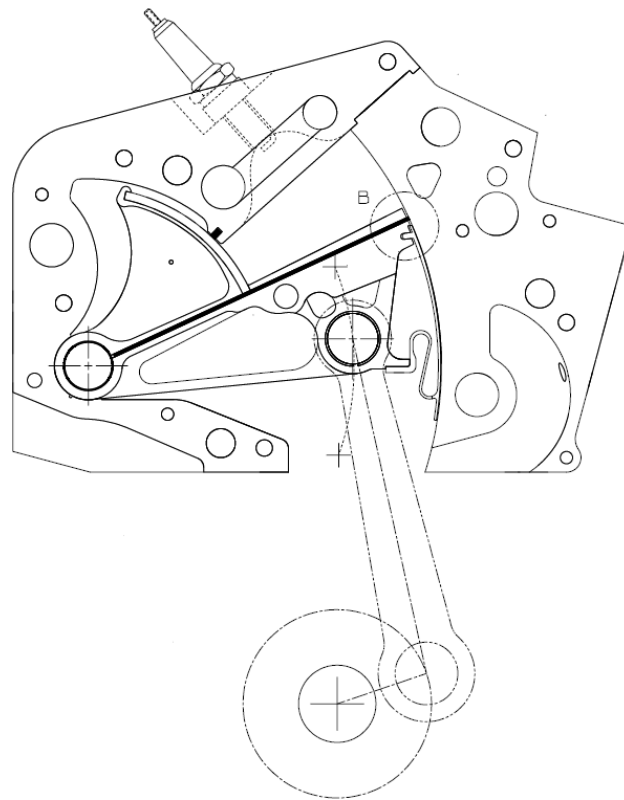

Source: Pivotal Engineering

Fig. 1 – Pivotal piston (3)

This design change enables to further reduce piston friction in the cylinder, what further improves the engine's efficiency. The lubricant consumption is reduced by 90% in comparison with a traditional two-stroke piston engine. In order to improve the reliability the piston is designed hollow with a cooling passage for water, additional cooling capability improves the engine durability.

Pivot engineering built several engine prototypes. First single combustion chamber prototype with volume 264 cm^3 was able to operate continually in 7000 RPM. Next prototype was the motorcycle two chambers engine with volume 400 cm^3 that was capable to reach 11500 RPM. Next developments are oriented to an experimental plane engine prototype.

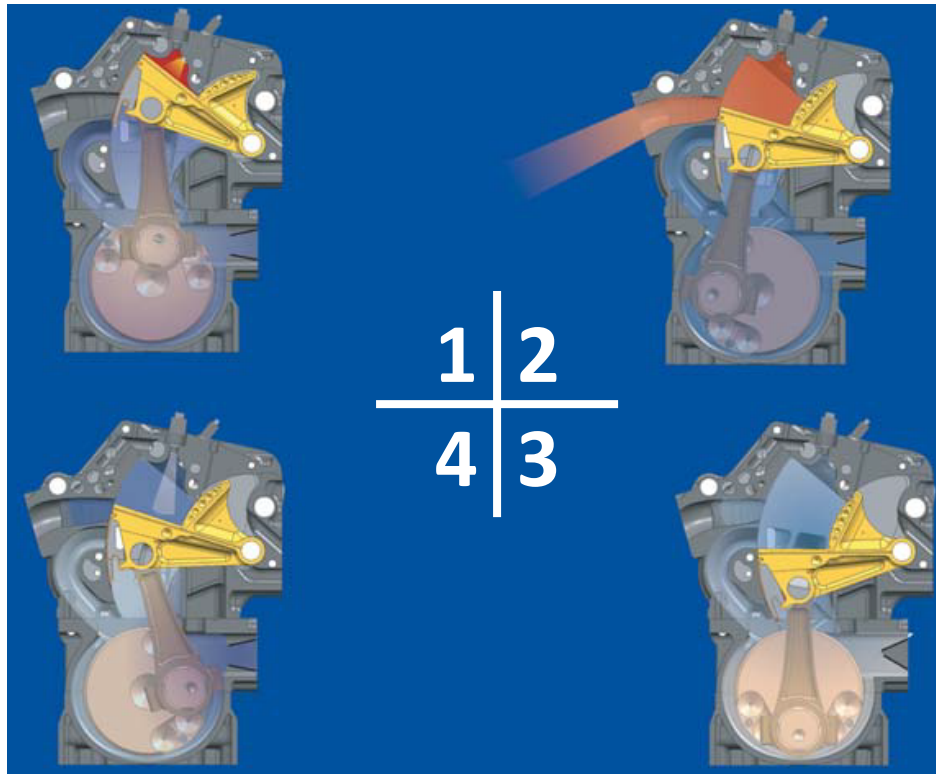

Source: Pivotal Engineering

Fig. 2 – Phases of the pivotal engine cycle

Work cycle of the pivotal engine (see Fig. 2):

1. Fresh charge is compressed and ignited by the spark plug, intake of the fresh air into crank case by the piston move upwards is finished.
2. Expanding gases are pushing the pivot piston down until the exhaust port is open, through which the burned charge escapes the cylinder. At the same time the fresh air is being compressed in the crank case.
3. Piston further moving down opens the transfer port through which the fresh air will get from the crank case into cylinder and help to finish the scavenging process of the previous cycle charge.
4. Fresh air is being sucked into crank case through the reed valve by vacuum caused by the piston moving up. When the fresh air is fully compressed the high pressure injector injects the fuel into the combustion chamber.

1.3 Case study Lotus Omnivore

In 2008 company Lotus Engineering in cooperation with Queen's University Belfast and company Jaguar Cars started to develop the experimental two-stroke engine Lotus Omnivore with target to reduce CO₂ emissions through a new design and utilization of the flex-fuel³ (4). Experimental single cylinder engine with bore 86 mm and stroke 86 mm is

³ Flex-fuel is a blend of petrol and ethanol with up to 85% of ethanol

equipped with five intake ports and one exhaust port, exhaust port opening duration is regulated by a trapping valve. Engine has a variable compression ratio from 10,0:1 to 40,0:1, which is controlled by a movable counter piston in cylinder head. A spark plug is placed into the movable counter piston; fuel is delivered to the combustion chamber through the high pressure fuel injector.

Piston carries two pairs of piston rings: two pegged half-keystone compression rings which traverse the ports in the upper section, and a napier scraper ring and u-flex oil control ring in separate grooves in the piston bottom section. With these piston rings the cylinder is completely sealed from the crankcase and wet sump lubrication might be used instead of more expensive dry sump lubrication.

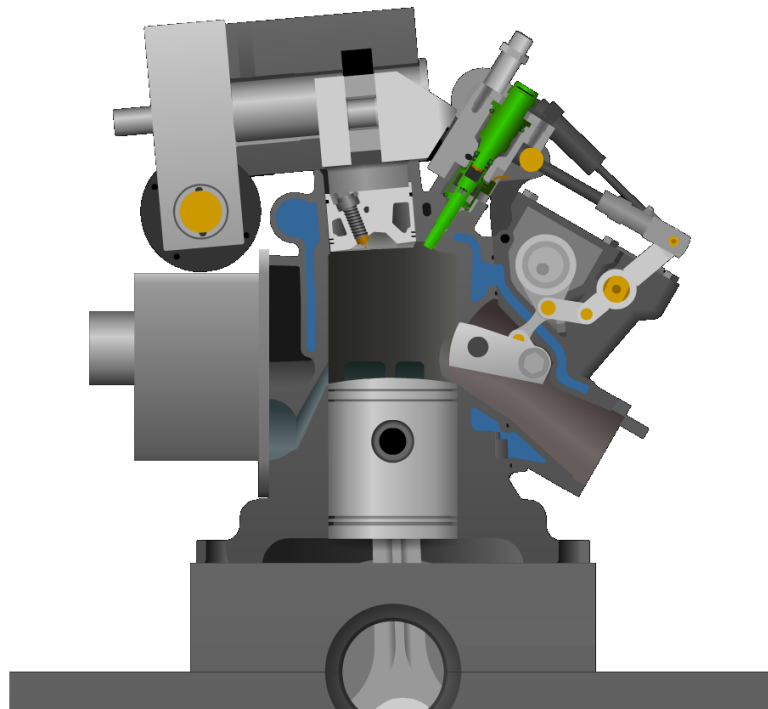

Source: Lotus Engineering

Fig. 3 - Architecture of the uniflow two-stroke engine with intake process control systems, piston depicted in both BDC and TDC positions

Engine control unit controls the engine setup based on the engine load, RPM and percentage of ethanol in flex-fuel. Engine is started with high compression ratio employing the spark plug. After the working temperature is reached the engine is operated in low RPM in homogeneous charge compression ignition mode. Compression ratio is still high and the trapping valve shortens duration of the exhaust port opening to keep the remains of the previous cycle charge to the next cycle.

With increasing the engine load and RPM to the middle range the engine configuration alters. The compression ratio is lowered and trapping valve extends the opening duration to improve engine's scavenging.

Further increasing the engine load and reaching the high RPM range lowers the compression ratio into levels where no compression ignition is possible and the engine control

unit must start ignition with spark plug. Trapping valve's opening duration is maximized to enable full scavenging potential at maximum load and RPM.

Omnivore engine is capable to run in any ratio of petrol / ethanol blend, based on the mixture the operational compression ratio range is being changed. The compression ratio is higher for higher ethanol percentage in the flex-fuel blend.

Lotus Engineering researches achieved great results, during initial test phase the fuel consumption was reduced by 10% when comparing with other direct fuel injection technology. Comparison of fuel consumptions for different direct fuel injection engines is in Fig. 4.

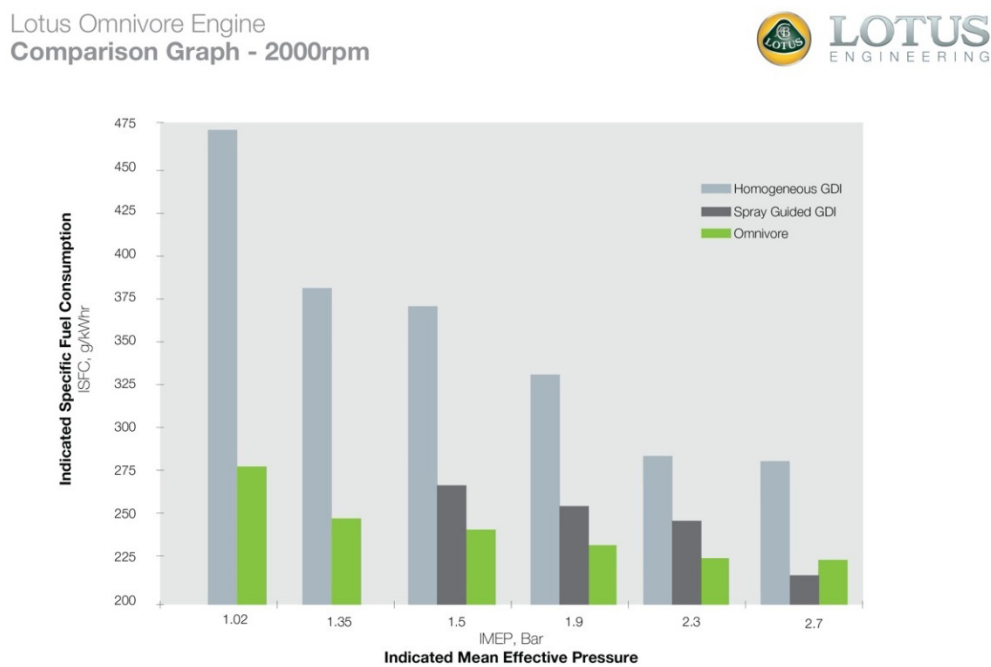

Source: Lotus Engineering

Fig. 4 – Comparison of Lotus Omnivore engine indicated specific fuel consumption with other direct fuel injection architectures

2. NEW TWO-STROKE COMBUSTION ENGINE CONCEPT - REVERSE UNIFLOW

2.1 Two-stroke engine designed with typical four-stroke engine control systems

Turning design of the current four-stroke engine into similar engine operating in the two-stroke cycle needs substantial design alterations. Based on the information gathered from literature (5) and (6) reverse uniflow engine architecture for personal vehicles was proposed. The main changes are: exhaust port placed at the bottom of the cylinder wall, supercharger delivering the compressed air charge.

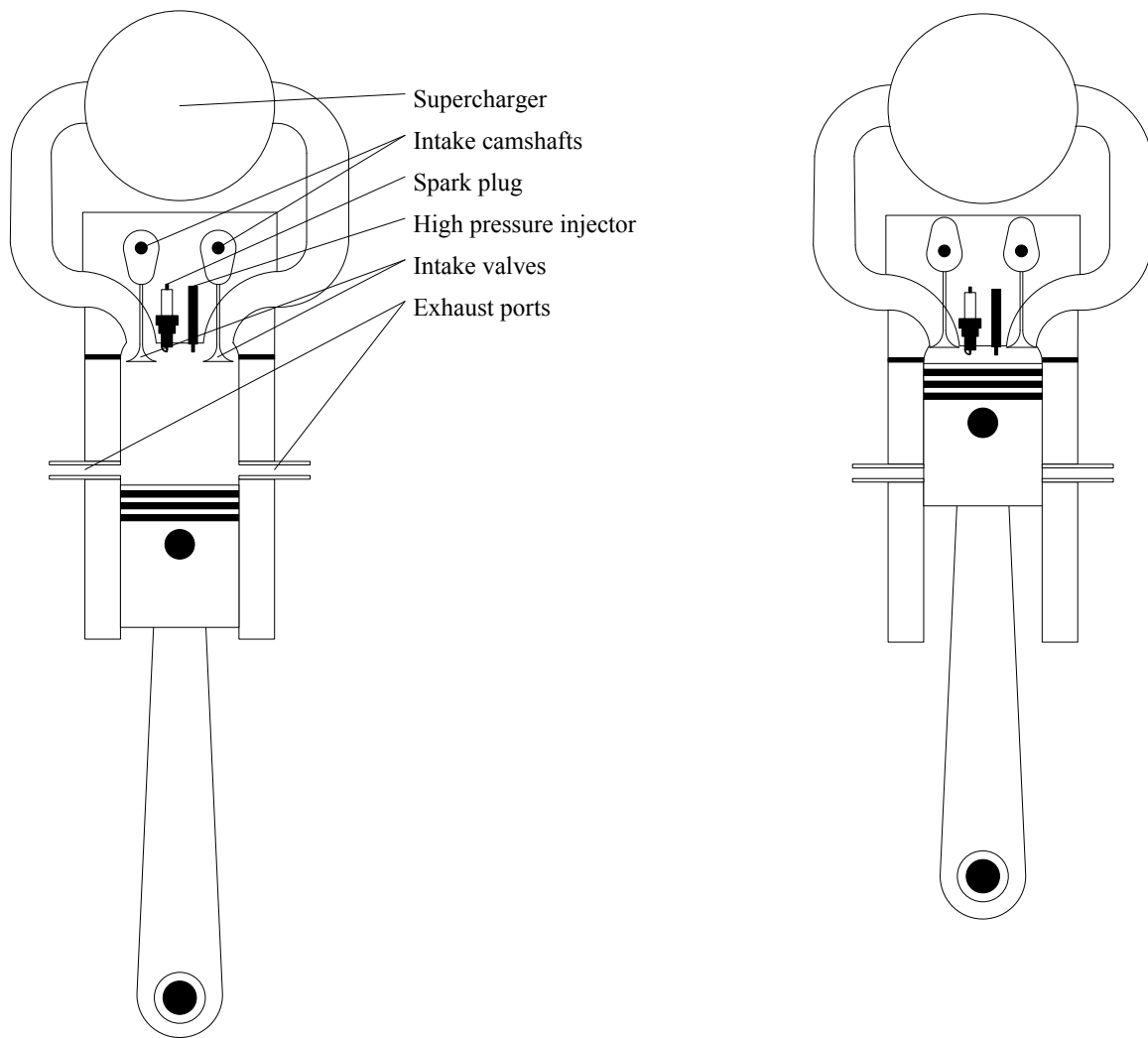

Source: Author

Fig. 5 - Architecture of the uniflow two-stroke engine with intake process control systems, piston depicted in both BDC and TDC positions

For engines with the inline configuration of cylinders the exhaust ports could be placed on both sides of the cylinder wall. On V engines or other more complex engine configurations, the exhaust ports must be placed on one side only. The piston height must be higher than the cylinder stroke in order to cover the exhaust port by the piston skirt when the piston travels near the TDC position and prevent lubricant escape from the crank case to the exhaust pipe.

Because no two-stroke engine generates vacuum in the cylinder during any part of the working cycle, the pressure gradient of the air charge leading to the cylinder must be created by external means. In classic two-stroke engine design this pressure gradient is generated between the crank case with pressurized air charge and the cylinder when both exhaust port and transfer port are open. Pressurized exhaust gases are leaving the cylinder through the exhaust port to the atmospheric pressure. The fresh pressurized charge from the crank case is flowing to the cylinder through the transfer port, where the pressure of the exhaust gases is dropping at the same time.

In the two-stroke engine architecture described above the pressure gradient is created by an external supercharger that is driven from the crankshaft by a belt. This form of forced induction ensures the boost is created from zero RPM, therefore allowing the engine to start and then operate at the whole range of RPM.

This engine architecture could be applied to both compression ignition engines as well as spark ignition engines.

2.2 Valvetrain

At least one intake valve must be used for fresh air charge delivery into cylinder. Majority of the current four-stroke engines utilize four valves (two intake and two exhaust valves) actuated by the DOHC valvetrain. Four valves are ideal compromise between development complexity and achieved flow of the gases exchange.

DOHC valvetrain allows independent control over two pairs of intake valves in the reverse two-stroke uniflow engine. Employing additional variable valve timing system would help to achieve particular goals such as maximizing power output, improved fuel economy or pollution control depending on engine operational mode.

Camless valve actuation systems are not massively used in automotive industry yet, however this technology would maximize the potential of valve control. As of 2014 only Fiat and Alfa Romeo equip some of their vehicles with engine from the MultiAir series, in which the intake valves are actuated by a solenoid instead of a camshaft.

2.3 Forced air induction

Reverse uniflow two-stroke engine cannot operate in purely naturally aspirated mode due to missing pressure gradient leading to the cylinder during intake stroke. Supercharger unit must be used to create enough boost to provide such pressure gradient at least in low RPM. For higher output desired in mid and upper RPM range a turbocharger might be employed to deliver even higher level of charge boost, utilizing the waste energy of the exhaust gases leaving the cylinder.

Variable valve timing combined a with multi-stage boost control mechanism, when the low boost charge from the supercharger will be entering cylinder through one pair of valves and the high boost charge from the turbocharger will be entering cylinder through the other pair of valves. This multi-stage boost control mechanism via intake valves will allow desired scavenging results and ensure no waste of the high pressurized charge through the exhaust port, what is necessary for high fuel combustion efficiency.

2.4 Fuel preparation system

One of the several classic two-stroke engines parasitic losses and high HC emission reasons is caused by amount of fresh air / fuel charge escaping the cylinder through the exhaust port during the scavenging process. The countermeasure to minimize such loss of the fresh charge (that might be better utilized during the combustion for an additional energy

gain) is the specifically tuned exhaust pipe, however this solution cannot completely avoid such parasitic loss.

Ideal answer to this problem is the direct fuel injection system, which injects the fuel to provide the fuel / air mixture mist at the time when the air charge is fully compressed in the combustion chamber. With the direct fuel injection no unburned fuel is expelled through the exhaust port during the scavenging process.

CONCLUSION

Modern control systems of four-stroke internal combustion engines such as direct fuel injection and variable valve timing could be used in two-stroke cycle engines with the aim to improve efficiency and lower exhaust gases pollutants. With the double amount of power strokes per revolution compared to similar four-stroke engine, the new two-stroke architecture enables a further step of passenger car engine downsizing.

The two-stroke cycle could be utilized in engines burning different fuels in both spark ignition engines and compression ignition engines.

A basic level of forced induction provided by a supercharger is necessary to start the engine and maintain the air charge gradient leading into engine's cylinder. The multistage forced induction system employing the turbocharger will allow increased power output from middle to high RPM.

The future research at Brno University of Technology Institute of Automotive Engineering will be focused on proof of concept of the new design of reverse uniflow two-stroke engine with the intake process control systems and finding technical solutions for the new design elements.

ACKNOWLEDGEMENT

This work is an output of research and scientific activities of NETME Centre, regional R&D centre built with the financial support from the Operational Programme Research and Development for Innovations within the project NETME Centre (New Technologies for Mechanical Engineering), Reg. No. CZ.1.05/2.1.00/01.0002 and, in the follow-up sustainability stage, supported through NETME CENTRE PLUS (LO1202) by financial means from the Ministry of Education, Youth and Sports under the „National Sustainability Programme I“.

REFERENCES

- (1) ENVIROFIT. *Factsheet MAINSTREAMING CONSERVATION & RENEWABLES*. Basel: World Clean Energy Awards, 2007. [online] [cit. 2014-03-30]. Available from: http://jawamania.info/Files/tech/223903/Design_of_a_Direct_Injection_Retrofit_Kit_for_Small_Two_Stroke_Engines.pdf

- (2) PIVOTAL ENGINEERING. *The High Power Density Pivotal Engine*. Christchurch, New Zealand, 2005. [online] [cit. 2014-03-30]. Available from: <http://www.pivotalengine.com/PivotalBrochure.pdf>
- (3) PIVOTAL ENGINEERING. *Pivotal Piston*. Christchurch, New Zealand, 2005. [online] [cit. 2014-03-30]. Available from: <http://www.pivotalengine.com/PivotalPiston.pdf>
- (4) LOTUS ENGINEERING. *Tisková zpráva*. [online] [cit. 2014-03-30]. Available from: <http://www.lotuscars.com/gb/engineering/case-study-omnivore-research-engine>
- (5) K. Morikawa, H. Takimoto. *Development and Evaluation of a Reverse Uniflow-Type Two-Stroke Gasoline DI Engine*. Pisa, Italy: Small Engine Technology Conference and Exhibition, 2001. SAE Technical Paper 2001-01-1839/4239.
- (6) Y. Moriyoshi, M. Arai, J. Katsuta, K. Morikawa. *Performance Tests of Reverse Uniflow-Type Two-Stroke Gasoline DI Engine*. Graz, Austria: Small Engine Technology Conference and Exhibition, 2004. SAE Technical Paper 2004-32-0040/ JSAE 20044327.